

RECOMMENDED COMPUTER SETTINGS FOR THE FOLLOWING POPULAR TRANSMITTERS

FF8 SUPER (Helicopter Version)

SET INHIBIT SET ON GAIN CHANNEL GAIN SWITCH ATV VALUE (RUDDER CHANNEL) ATV VALUE (GYRO GAIN CHANNEL)	GYRO SENSE/ REVOLUTION / CHANNEL 5 CHANNEL 5 50-120% (BOTH DIRECTION) CHANNEL 5 0-100% (BOTH STANDARD AND TAIL LOCK MODE) SUB - TRIM TRIM SERVO TO NEUTRAL POSITION FP-9203 OR FP-9205
RUDDER TRIM	
FAST SERVO RECOMMENDED	

FF7 AND FF8 (Helicopter Version)

SET INHIBIT SET ON GAIN CHANNEL GAIN SWITCH ATV VALUE (RUDDER CHANNEL) ATV VALUE (GYRO GAIN CHANNEL)	REVOLUTION / CHANNEL 5 CHANNEL 5 50-120% (BOTH DIRECTION) CHANNEL 5 0-100% (BOTH STANDARD AND TAIL LOCK MODE) SUB - TRIM TRIM SERVO TO NEUTRAL POSITION FP-9203 OR FP-9205
RUDDER TRIM	
FAST SERVO RECOMMENDED	

JRX388 /SX3810 /X8103 (Helicopter Version)

SET INHIBIT SET ON GAIN CHANNEL GAIN SWITCH ATV VALUE (RUDDER CHANNEL) ATV VALUE (GYRO GAIN CHANNEL)	GYRO SENSE/ REVOLUTION (TAIL MIXING) / AUX2/ RUDDER DUAL RATE AUX2 50-150% (BOTH DIRECTION) AUX2 0-100% (BOTH STANDARD AND TAIL LOCK MODE) SUB-TRIM TRIM SERVO TO NEUTRAL POSITION JR2700G OR SUPER SERVO
RUDDER TRIM	
FAST SERVO RECOMMENDED	

JRPCM 10S/SX (Helicopter Version)

SET INHIBIT SET ON GAIN CHANNEL GAIN SWITCH ATV VALUE (RUDDER CHANNEL) ATV VALUE (GYRO GAIN CHANNEL)	CODE 44 GYRO SENSE CODE 47 REVOLUTION (TAIL MIXING) / AUX3 / RUDDER DUAL RATE AUX3 / RUDDER DUAL RATE 50-150% (BOTH DIRECTION) AUX3 CHANNEL 0-100% (BOTH STANDARD AND TAIL LOCK MODE) CODE 15 STM SUB-TRIM TRIM SERVO TO NEUTRAL POSITION JR2700G OR SUPER SERVO
RUDDER TRIM	
FAST SERVO RECOMMENDED	

FU9ZHP/ZAP (Helicopter Version)

SET INHIBIT SET ON GAIN CHANNEL ATV VALUE (RUDDER CHANNEL) ATV VALUE (GYRO GAIN CHANNEL)	GYRO SENSE MODE THROTTLE TO RUDDER MIXING RUDDER TO GYRO MIXING 'P->R' PITCH TO RUDDER MIXING / CHANNEL 5 50-140% (BOTH DIRECTION) CHANNEL 5 0-100% (BOTH STANDARD AND TAIL LOCK MODE) STM SUB-TRIM TRIM SERVO TO NEUTRAL POSITION FP9203 OR FP9205
RUDDER TRIM	
FAST SERVO RECOMMENDED	

Use of Adhesive Foam during Gyro Installation

Vibration can do a lot of damage to a gyro, therefore it is important to mount the gyro to a surface where there is little vibration. It is also important to increase damping to the gyro, in order to decrease vibrations. For the best result, please follow these instructions for mounting the gyro using adhesive foam.

When installing the gyro, follow the steps regarding the use of adhesive foam below:

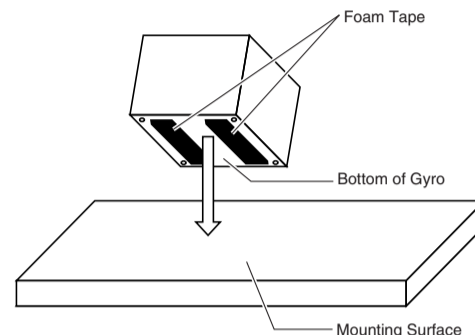

1. Find a position at or near the centre of mass of the R/C helicopter where there should be little vibration.
2. Clean the mounting surface and the bottom surface of the gyro using alcohol.
3. Using the two pieces of adhesive foam provided, attach one piece at each end of the bottom surface of the gyro, then adhere the gyro onto the mounting surface. Do not use one large piece of adhesive foam that covers the whole bottom of the gyro.

IMPORTANT: Do not use double-sided tape without foam padding.

It is important to replace the adhesive foam when it starts to become less adhesive, worn down, loose, etc. It is recommended that you use adhesive foam that is 3mm thick. An example of an adhesive foam which can be used is Telefoam, product no. 301. When removing the gyro to replace the adhesive tape, lever the gyro off the mounting surface such as a flat-head screwdriver, etc.

Ver 1.4

GR701 Tail Lock System

Warranty void if gyro sensor case or amplifier case has been opened.

The unit is sold as is. No modification service will be provided.

Proof of purchase must be presented when service is required.

INSTALLING THE GYRO SENSOR

Tape the Gyro Sensor down using the supplied foam tape with the label up. Make sure the gyro is on a solid platform, and in a well ventilated area, away from exhaust and or heat.

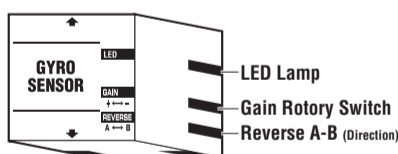

CABLE CONNECTIONS FOR GYRO Control Amplifier

Simply connects the Gyro Control Amplifier in series between receiver and servo.

Single Mode Connections :

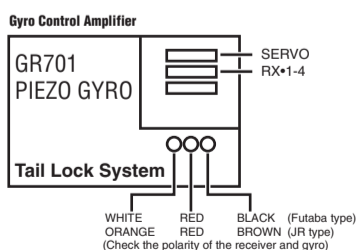

Step 1: Connect the rudder servo to the "SERVO" connection at the gyro control amplifier. An extension may be necessary.

Step 2: For Futaba PPM/PCM Radio Transmitter: Connect the cable from "RX*1-4" of the gyro control amplifier to the "Channel 4" of the Receiver.

For JR PPM/SPCM/ZPCM Radio Transmitter: Connect the cable from "RX*1-4" of the gyro control amplifier to the "RUDD" of the Receiver.

Table of Connections :

		RX*1-4 connect to receiver's
Radio Transmitter	JR PPM/SPCM	"RUDD"
Radio Transmitter	Futaba PPM/PCM	Channel 4
Radio Transmitter	JR ZPCM	"RUDD"

Dual Mode Connections :

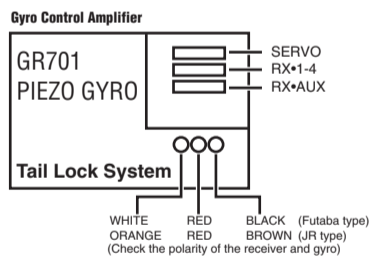

Step 1: Connect the rudder servo to the "SERVO" connection at the gyro control amplifier. An extension may be necessary.

Step 2: For Futaba PPM/PCM Radio Transmitter: Connect the cable from "RX*1-4" of the gyro control amplifier to the "Channel 4" of the Receiver.

For JR PPM/SPCM/ZPCM Radio Transmitter: Connect the cable from "RX*1-4" of the gyro control amplifier to the "RUDD" of the Receiver.

Step 3: For Futaba PPM/PCM Radio Transmitter: Connect the cable from "RX*AUX" of the gyro control amplifier to "CHANNEL 5" of the receiver.

For JR PPM/SPCM Radio Transmitter: Connect the cable from "RX*AUX" of the gyro control amplifier to "AUX2" or "AUX3" + ** of the receiver.

For JR ZPCM Radio Transmitter: Connect the cable from "RX*AUX" of the gyro control amplifier to "AUX2" + ** of the receiver.

Table of Connections :

		RX*1-4 connect to receiver's	RX*AUX connect to receiver's
Radio Transmitter	JR PPM/SPCM	"RUDD"	"AUX 2" or "AUX 3" + **
Radio Transmitter	Futaba PPM/PCM	Channel 4	Channel 5
Radio Transmitter	JR ZPCM	"RUDD"	"AUX 2" + **

JR TYPE

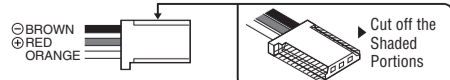

SETTING UP

1. Switch on your transmitter.
2. Switch on your helicopter's receiver and DO NOT move the helicopter body until the LED on the gyro sensor lights up. (It takes few seconds to light up.)
3. Set up your transmitter

For Dual Mode (Tail Lock and Standard) :

Set OFF the following functions (if there is any) of your transmitter:

- ATS (Automatic tail stabilization)
- Pilot authority mixing
- Throttle to rudder mixing
- Rudder to gyro mixing
- Pitch to rudder mixing
- Revolution mixing

For Single Mode (Standard Mode) :

Set ON for the following functions (if there is any) of your transmitter:

- ATS (Automatic tail stabilization)
- Pilot authority mixing
- Throttle to rudder mixing
- Rudder to gyro mixing
- Pitch to rudder mixing
- Revolution mixing

4. Set the direction switch A ↔ B on the gyro sensor to make tail pitch move to the right compensation.

5. Gain Control

Single mode : Adjust the gain control+ ↔ - on the gyro sensor (by using the small screwdriver to tune the rotary switch), to obtain maximum performance.

Dual mode : Adjust the gain control on transmitter Gyro gain channel of ATV to obtain maximum performance.

TRIM ADJUSTMENT OF RUDDER BEFORE FLYING

(For dual mode setting only)
In order for the gyro to function properly, it is utmost importance to trim the gyro properly.

1. Set the rudder trim (and sub-trim if available) to neutral.
2. Identify the gyro gain switch position on your transmitter which gives the standard gain mode and the tail-lock mode. (This can be done by observing the rudder servo behavior by applying full rudder command followed by release: in the standard gain mode, the rudder servo will return rapidly to the neutral position when the rudder stick is released, whereas in the tail lock mode, the rudder servo will tend to remain at its full travel limit).
3. Set the gyro gain switch to the tail-lock mode: you will find that the **RUDDER SERVO WILL CREEP IN ONE DIRECTION**.
4. Set the rudder trim (or preferably the sub-trim) so that the creep in the rudder servo is minimized. You will find that there will still be some slow residual creeping which is normal. This slow residual creeping will take 10 to 20 seconds for the rudder serve to full travel.
5. Once this trim position has been found, no further adjustment should be needed. However, some slight

adjustment of the tail control linkages may still be needed in order to reduce any offset effects in the standard gain mode. (This could only be done through flight trials).

6. Select the tail-lock mode and hover the helicopter.
7. Applying short stabs to the rudder control and see whether there is any tendency for the tail to oscillate. Reduce the gyro gain if oscillation is seen. Conversely, increase the gain if no oscillation is seen. (The aim of to use the highest possible gain without introducing oscillation)
8. Observe, any trim offset in the tail and correct with the rudder trim.
9. Select the standard gain mode and repeat the exercise. In this case, any offset effects should be corrected by adjusting the tail rotor linkages.

IMPORTANT :

1. If after adjusting the gyro gain with the transmitter and tail is still hunting slightly move the control link to a different position on the rudder servo disk (the extreme outside fourth position is recommended)

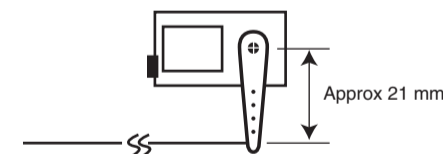

2. In order to let the gyro sensor adapt to the temperature and humidity of the flying field, it is strongly recommended to leave the gyro and receiver in ON position for at least 5 minutes, then switch on/off to reset the receiver afterward.

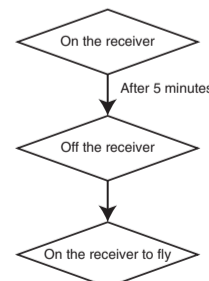

Cautions :

This device is not a toy. Safety is the top priority. We do not assume any liability for consequential damages as result of the product use, and in any event, our liability shall not exceed the original price of the device unit.

* ALL BRAND NAMES AND TRADEMARKS ARE THE PROPERTY OF RESPECTIVE OWNERS.
* SPECIFICATIONS SUBJECT TO CHANGE WITHOUT NOTICE.

Ver 1.4